

The following installation details apply to models **FSD-141, FSD-142, FSD-143, FSD-151, FSD-152, FSD-171 and FSD-172**

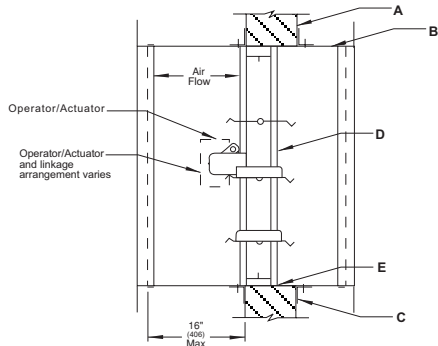

Vertical Mount

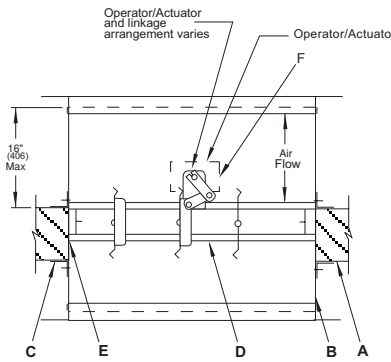

Horizontal Mount



- Notes:**
- All dimensions shown in () are in millimeters.
 - Illustration depicts damper installed vertical right side up. Damper may also be installed upside down.

Illustrations show triple-V bladed (140/170 type), steel airfoil blade (150 type) similar.

- Illustration depicts damper installed from the top down with the actuator above the floor line. Damper may also be installed from the bottom up with the actuator below the floor line.

- A.** Concrete or masonry fire partition shown. See Wood Stud and/or Steel Stud Framing for Fire Dampers In Drywall and/or Cavity Shaftwall Partitions Supplemental Installation Instructions for further vertical mount installation details. The opening shall be a minimum of 1/4" (6) with a maximum of 3/4" (19) larger than the overall damper and sleeve assembly size. When openings are larger than 3/4" (19), but less than 6" (152) the mounting angles must be a minimum of 16 gauge (1.5) and must be tall enough to overlap the opening by a minimum of 1" (25). Damper must be installed with leading edge of closed blade within the partition.
- B.** For rigid type duct connections, the sleeve shall be a minimum of 16 gauge (1.5) for dampers up to 36" wide by 24" high (914 x 610) and 14 gauge (1.9) for larger units. When lighter gauge sleeves are used, one or more of commonly used breakaway style connections are required. Refer to Sleeve Termination Supplemental Installation Instructions for further details. In no case will the sleeve gauge be less than the duct gauge to which it is connected. Damper sleeve shall not extend more than 16" (406) beyond the rated partition on the actuator side. The opposite side extension shall be a maximum of 6" (152) unless an access door is installed in the sleeve which then permits the extension to be a maximum of 16" (406).
- C.** Mounting angles shall be a minimum of 3/4" x 1-1/2" tall x 20 gauge (19 x 38 x 1.0). For opening sizes ≤ 80" wide (2032), 96" high (2438), and not exceeding 26.67 square feet in area retaining angles are only required on one side of the partition and must be attached to the sleeve and the partition. For larger openings (or optional on smaller openings), or horizontal mountings 1-1/2" x 1-1/2" x 16 gauge (38 x 38 x 1.5), retaining angles are required on both sides of the partition and must be attached to the sleeve. Attachment to the sleeve shall be with No. 10 (M5) diameter steel rivets, Quick-Lock joints or welds, at 12" (305) o.c. maximum. Attachment to partition/opening shall be with min. #10 fasteners with a minimum length as follows: For metal stud and the angles under the drywall, the fasteners must be a min. 1/2" long. For metal stud and the angles over the drywall the fastener must be a min. 1/2" longer than the thickness of the drywall. i.e. if the partition has one layer of 5/8" drywall on the attachment side, the screws must be 1/2" + 5/8" = 1-1/8" long. For wood stud openings, the min. length is 1-1/2" longer than the thickness of drywall on the attachment side. For concrete or masonry openings, the anchors must be min. #10 fasteners- screws or bolts. In lieu of masonry anchors and bolts/screws, self-tapping masonry screws can be used. The fasteners in the partition should be located such that they are 1/2" below the top of the 1-1/2" flange of the retaining angles. Fasteners in the partition should be spaced 12" o.c. max. A minimum of two connections per side, top and bottom. A minimum 3/4" 20 gauge (19 x 1) flange termination may be used in lieu of mounting angles. Refer to Sleeve Termination Supplemental Installation Instructions and Framing for Fire Dampers for further details. Ensure that attachment device does not interfere with the operation of the damper and the free movement of the damper blades.
- D.** When joining multiple sections or fastening the damper to the sleeve, the damper shall be fastened with 3/16" (4.8) diameter steel rivets, Quick-Lock Joints, welds or No. 10 (M5) bolts or sheet metal screws at 8" (203) o.c. maximum. A minimum of two connections per side, top and bottom. For vertical FSD-141, 142, 143, and 151 installations >108" w x 96" h, a supplemental support mullion is required. The mullion must be a flat steel plate minimum 14 gauge thick and 5" wide. The mullion should be the same length as the opening/duct height. The mullion must be installed between the damper frames of the dampers running parallel to opening/duct height located at the center of the assembly. For horizontal FSD-151 installations more than one damper high, a supplemental support mullion is required. The mullion must be a flat steel plate minimum 14 gauge thick and 5" wide. The mullion should be the same length as the opening/duct height. The mullion must be installed between the damper frames running parallel to the opening/duct height. The mullion is required between the damper frames on the interior dampers only. If the damper frames are attached directly to the damper sleeve, no mullion is required. Supplemental support mullions should be attached to the damper frames using any of the same fasteners indicated previously in this section.
- E.** A continuous bead of Dow-Corning 700 or 732, or GE RTV 108 or SCS 1201 RTV silicone rubber sealant shall be applied between the damper and the sleeve and between sections of a multiple damper assembly. Sealant is only required on one side of the damper.
- F.** Fire/Leakage rated dampers and qualified operators are tested together by Underwriters Laboratories and are factory installed to qualify for standard damper/operator warranties. Damper operator/actuator must be tested prior to system start-up to ensure proper operation. Before applying power to the operator/actuator, the power must be verified.

Note: The annular space between damper sleeve and wall opening must not be filled with firestop materials such as fill, void, or cavity materials. However, if optional sealing between the retaining angle (or flange) leg and the surface of the partition, wall, or floor and/or between the retaining angle leg and the surface of the damper sleeve is required, any of the following sealants may be used:

Dow-Corning 700 or 732 GE RTV 108 or SCS 1201 RTV

These sealants must be applied such that they do not intrude into the annular space between the outside surface of the damper sleeve and the opening of the partition, wall or floor into which the damper/sleeve is being installed.

The following table applies to models FSD-141, FSD-142, FSD-143, FSD-151, and FSD-152 only.

DUCT SIZES	GALVANIZED STEEL				STAINLESS STEEL	
	VERTICAL		HORIZONTAL		VERTICAL	HORIZONTAL
	FSD-141, 142, 143	FSD-151, 152	FSD-141, 142, 143	FSD-151, 152	FSD-141, 142, 143	FSD-141, 142, 143
Maximum Single Section	36" x 48" (914 x 1219)	32" x 48" (813 x 1219)	36" x 48" (914 x 1219)	30" x 50" (762 x 1270)	36" x 48" (914 x 1219)	36" x 48" (914 x 1219)
Maximum Multiple Section	144" x 96" (3658 x 2438)	144" x 96" (3658 x 2438)	108" x 48" (2743 x 1219)	144" x 96" (3658 x 2438)	72" x 48" or 36" x 96" (1829 x 1219 or 914 x 2438)	72" x 48" or 36" x 96" (1829 x 1219 or 914 x 2438)

The above information for dampers installed in a vertical fire separation pertains to those where the damper blades are horizontal. However, as an exception, if the dampers are Model FSD-141 and are 6" (152) wide by 6" (152) high, they may be installed with the blades in a vertical orientation. All other installation details are as outlined above except that the mounting angle on the top of the damper sleeve needs only to be a minimum of 3/4" (19) tall.